



MTS 242 Hydraulic Actuator

Operates under precision servovalve control in MTS closed-loop servohydraulic systems

be certain.

MTS 242 HYDRAULIC ACTUATORS ARE SMALL, LOW FORCE,
LINEAR ACTUATORS WHICH OPERATE UNDER PRECISION SERVOVALVE
CONTROL IN MTS CLOSED-LOOP SERVOHYDRAULIC SYSTEMS. TYPICAL
APPLICATIONS INCLUDE COMPONENT FATIGUE TESTS, STRUCTURAL
RESONANCE SEARCHING AND MODAL ANALYSIS.



242 Actuator

The 242 Actuator is available in four models. Each 242 Actuator has a standard stroke length of 4 or 6 in. (101.6 or 152.4 mm). Other stroke lengths are available as options (see Table 1). Force ratings for each model are as follows:

- » 242.00 0.6 kip (2.7 kN)
- » 242.01 1.0 kip (4.5 kN)
- » 242.02 2.2 kip (9.8 kN)
- » 242.03 3.3 kip (14.7 kN)

Each 242 Actuator contains a closed-housing LVDT (linear variable differential transformer) to provide an accurate

indication of piston rod displacement, and has a pedestal base which allows the actuator to be rigidly mounted to a reaction mass. The actuator may also be installed in an MTS load frame. A swivel mounting accessory is available and is typically used in structural testing applications where pivotal freedom of the actuator is necessary.

The 242 Actuator is designed for the severe requirements of servo-controlled, closed-loop testing applications without compromising long-term reliability. Lab tested and field proven, this design features the latest technology in seal and bearing materials.

Design Characteristics

All MTS actuators are carefully manufactured to close tolerances. This attention to precision ensures reliability, performance, long life, and complete part interchangeability (within a given actuator model). The following characteristics are common to all Series 242 Actuators (refer to Figure 1).

- 1. Piston Rod End** (fixture attachment end) has a center position internal thread for mounting fixtures, swivels, load cells, etc.
- 2. Porting:** High-pressure hydraulic fluid is supplied through the pressure port, marked on the actuator with a P. Internal passages direct the fluid to a servovalve. The servovalve sends the fluid to one side of the piston or the other in order to extend or retract the piston rod. As hydraulic pressure is applied to one side of the piston, the fluid on the other side is ported through the servovalve to the return port, marked on the actuator with an R.
- 3. Piston Rod** is a double-ended piston rod that has equal areas on both sides for balanced performance. It is machined from a single piece of heat-treated alloy steel, hard chrome plated, and precision ground to a fine finish to increase seal and bearing life. The hollow rod permits convenient installation and accurate alignment of the LVDT.
- 4. Piston Rod Bearings** are high-capacity nonmetallic bearings bonded directly to the end caps. The nonmetallic bearings are standard due to their high sideload tolerance and resistance to failure from galling and seizure.

The close tolerance fit between the piston rod and bearing surface creates a low leakage viscous seal. A small amount of hydraulic fluid is allowed to flow across the bearing for lubrication, and is then ported back to the system hydraulic power supply reservoir.

- 5. Piston Rod Seals** wipe excess hydraulic fluid from the piston rod and guide the fluid into the drainback port. One low-pressure seal is provided in each end cap.
- 6. Viscous Piston Seal** provides a close tolerance fit between the piston and cylinder. Grooves on the piston ensure adequate lubrication of the piston surface during short-stroke, sideloaded tests.
- 7. Cushions:** Hydraulic cushions protect the end caps during full-stroke, high-velocity operation.
- 8. LVDT Assembly** is internally mounted to provide a displacement indication of the actuator piston rod. The LVDT core is secured to the inside of the hollow piston rod by a locking setscrew and can be adjusted to establish a zero reference point for the actuator.
- 9. Pedestal Base** allows the actuator to be rigidly mounted to a reaction mass, or permits attachment of a swivel mounting accessory.

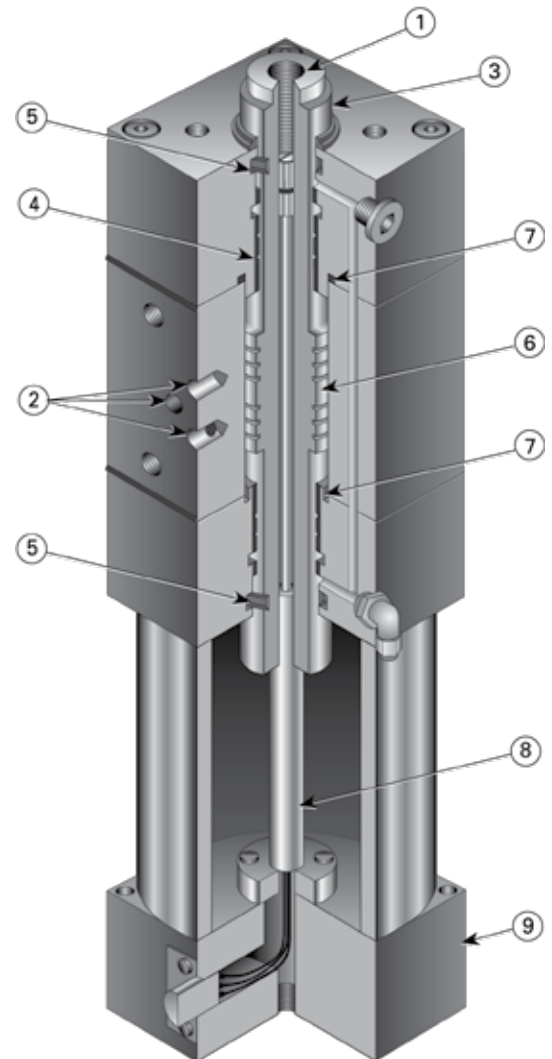

Figure 1. Cutaway View of a Typical Series 242 Actuator

Specifications and Dimensions

Specifications for the 242 Actuators are listed under the actuator model number in Table 1. Actuator and accessory dimensions are illustrated in Figures 2 and 3. Lettered dimensions called out in Figure 2 are listed in Table 2.

Table 1. Actuator Specifications

Model*	Force Rating [†]		Piston Area		Rod Diameter	
	kN	kip	mm ²	in. ²	mm	in.
242.00	2.7	0.6	0.21	137	28.6	1.12
242.01	4.5	1.0	0.42	270	28.6	1.12
242.02	9.8	2.2	0.91	590	28.6	1.12
242.03	14.7	3.3	1.18	760	28.6	1.12

* Each model has a standard stroke length of 101.6 or 152.4 mm (4 or 6 in.). This value is total stroke minus the total cushion length, 12.7 mm (0.50 in.). Optional stroke lengths are available in 25.4 and 50.8 mm (1.00 and 2.00 in.).

† Nominal force with 17.2 MPa (2500 psi) pressure drop across the piston. Actual force may be up to 20% higher depending on servovalve size and test conditions.

Specifications are subject to change without notice. Contact MTS for verification of specifications critical to your needs.

Table 2. Actuator Dimensions

Stroke (All Model)		A		B		C (Rod-Eye Bearing Swivel)		D (Closed Housing)	
mm	in.	mm	in.	mm	in.	mm	in.	mm	in.
25.4	1	41.4	1.63	215.9	8.50	322.2	12.69	308.0	12.13
50.8	2	66.8	2.63	215.9	8.50	347.6	13.69	333.4	13.13
101.6	4	117.6	4.63	279.4	11.00	461.9	18.19	447.7	17.63
152.4	6	168.4	6.63	330.2	13.00	563.5	22.19	549.3	21.63

* The Dimensions listed are shown in Figure

Dimensions are subject to change without notice. Contact MTS for verification of dimensions critical to your needs.

FEATURES

- » Available with force ratings of 2.7, 4.5, 9.8, or 14.7 kN (0.6, 1.0, 2.2, or 3.3 kip)
- » Nonmetallic bearings provide high sideload capabilities and eliminate bearing-to-rod galling failures
- » Accepts a wide range of MTS Series 252 Servovalves, with flow ratings from 4 to 57 L/min (1 to 15 gpm)
- » Standard Series 242 Actuators use low-pressure piston rod seals. This provides low friction operation, while minimizing fluid leakage and keeping contaminants out of the actuator
- » The single-piece, chrome-plated, hollow piston rod is constructed to provide strength and extended seal and bearing life
- » Built in hydraulic cushions protect the end caps during full-stroke, high-velocity operation
- » The displacement transducer is coaxially mounted in the hollow piston rod for increased accuracy and transducer protection

Options

All MTS actuators are carefully manufactured to close tolerances. This attention to precision ensures reliability, performance, long life, and complete part interchangeability (within a given actuator model). The following characteristics are common to all Series 242 Actuators (refer to Figure 1).

- » Each 242 Actuator has a standard stroke length of 101.6 or 152.4 mm (4 or 6 in.). Other stroke lengths are available as options (refer to Table 1).
- » **Special Porting:** Series 242 Actuators may be ordered with porting designed to accommodate flow requirements greater than the maximum 57 L/min (15 gpm) recommended for the standard Series 242 Actuators. Contact MTS Systems Corporation for information on special flow requirements.
- » **High-Pressure Seals:** An optional high-pressure seal kit is available and may be used to increase the efficiency of the actuator during static test applications. One high-pressure seal is installed in each end cap, reducing the amount of fluid that flows across the piston rod bearings. Another high-pressure seal is installed on the piston, to reduce the amount of fluid transfer across the viscous piston seal. High-pressure seals are not recommended for high-velocity dynamic applications. High-pressure seal kits may be ordered with a new actuator or may be ordered separately and added to an existing actuator.

Swivel Mounting Accessories

The rod-eye bearing swivel mounting accessory consists of a swivel eye and a mounting bracket assembly. The swivel eye may be threaded into either end of the actuator, although the pedestal base LVDT assembly is required for swivel attachment to the lower end of the actuator. Two swivel mounting accessories are necessary to provide pivotal freedom of both ends of the actuator, reducing sideloads on the piston rod. The mounting bracket may be bolted to a fixture, or to a reaction mass, structural base, or bedplate.

The Series 249 Swivels are typically used for testing purposes where swivel movement with minimum backlash is required. The swivels can be mounted to a 242 actuator, when the closed housing LVDT assembly is utilized on the base of the actuator. A reaction mass, bedplate, or structural component may be attached to a mounted swivel. For structural testing applications, a 242 actuator equipped with both a swivel base and swivel rod end provides pivotal freedom at both ends of the actuator.

Figure 3 provides the specifications and dimensions for the swivel mounting accessories.



Ordering Information

When ordering a Series 242 Hydraulic Actuator, first specify the desired actuator by the model number corresponding to the force rating, and the required dynamic stroke (refer to Table 1). Next, specify any additional options and accessories as follows:

- » Special Porting
- » High-Pressure Seals
- » Swivel Mounting Accessories

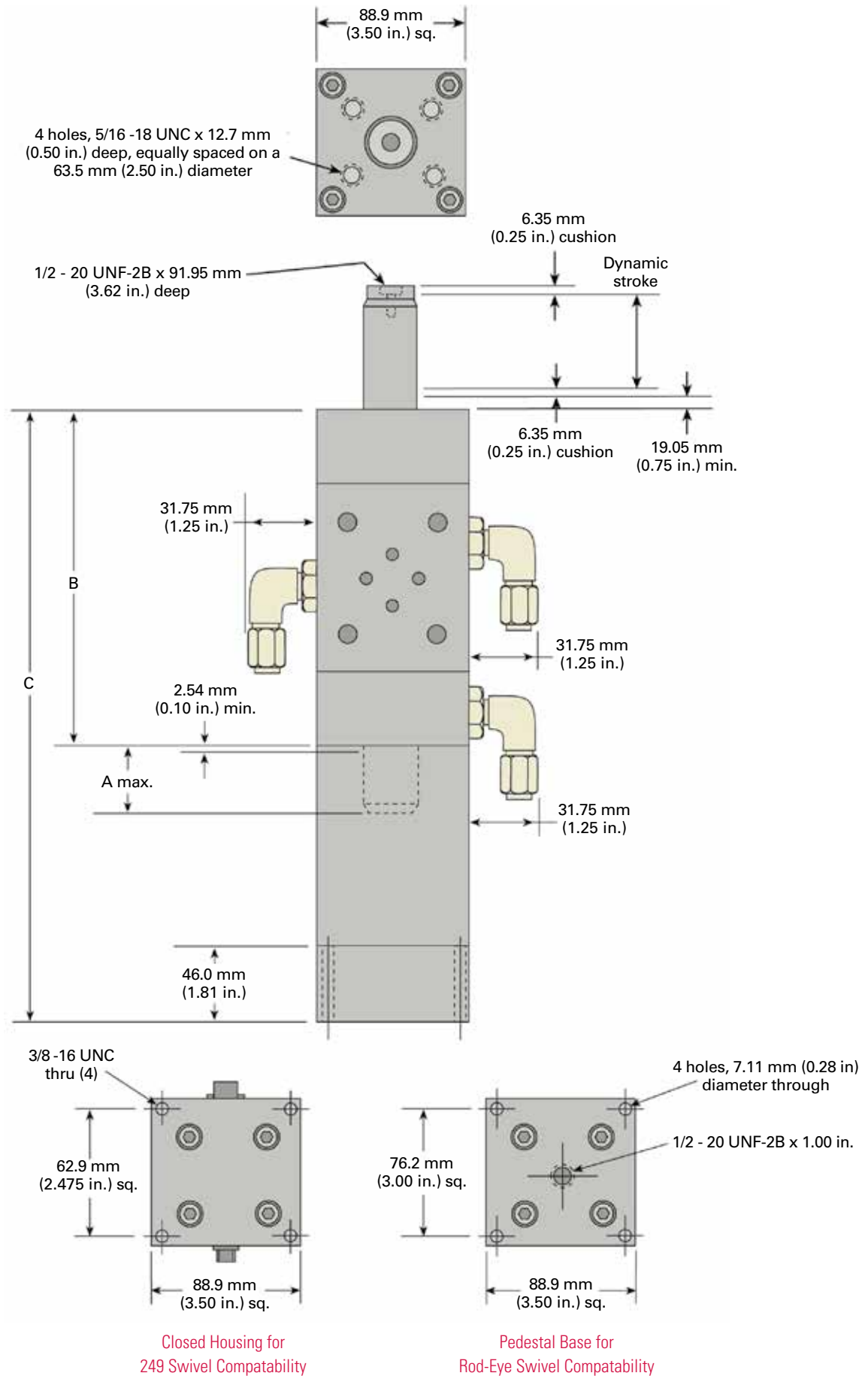

Figure 2. Basic Series 242 Hydraulic Actuator with Closed Housing LVDT Assembly or alternate Pedestal Base

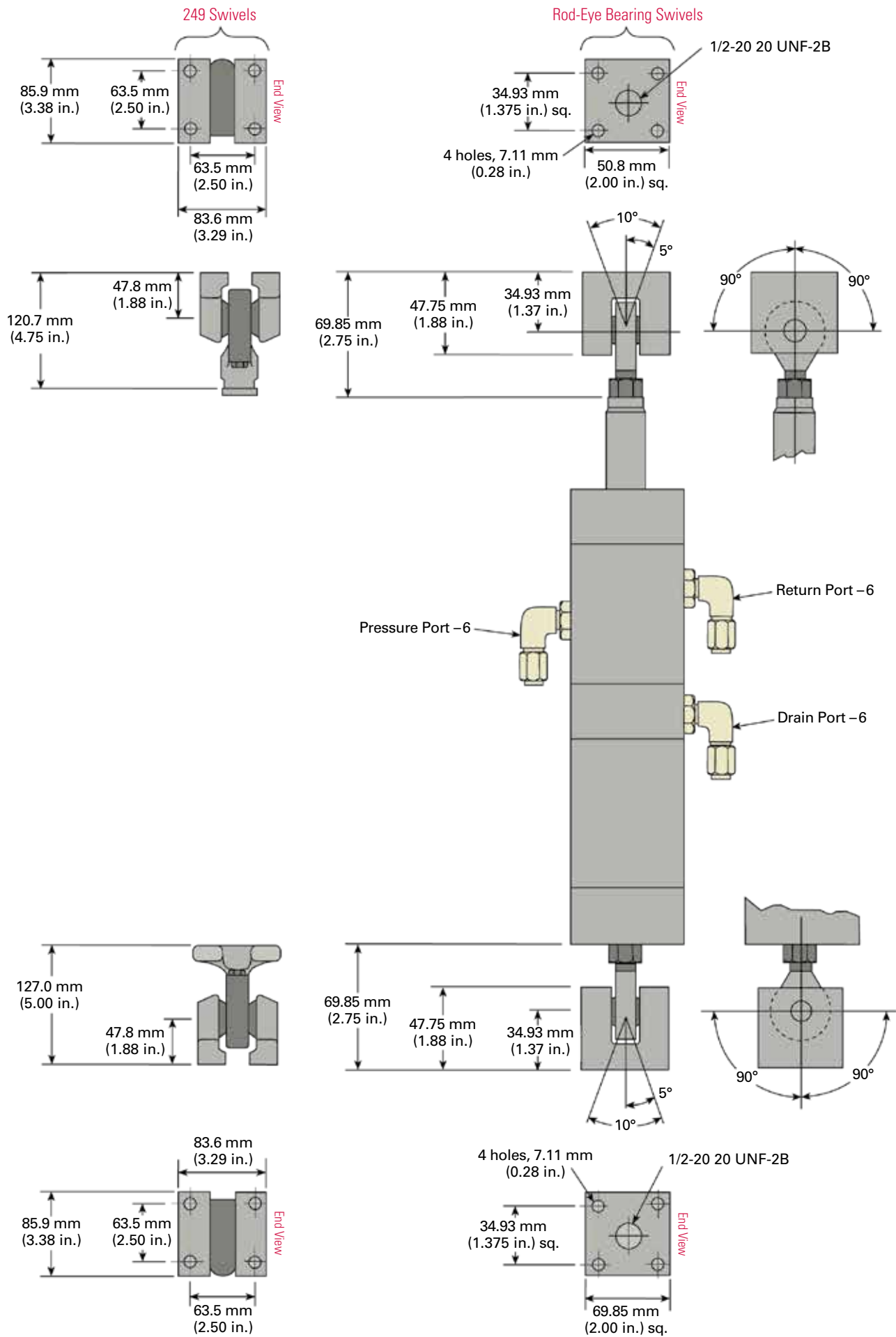

Figure 3. Series 242 Hydraulic Actuator with Swivel Accessories

Regional Business Centers

THE AMERICAS

MTS Systems

14000 Technology Drive
Eden Prairie, MN 55344-2290
USA
Telephone: 952-937-4000
Toll Free: 800-328-2255
E-mail: info@mts.com
Internet: www.mts.com

EUROPE

MTS Systems France

BAT EXA 16
16/18 rue Eugène Dupuis
94046 Créteil Cedex
France
Telephone: +33-(0)1-58 43 90 00
E-mail: contact.france@mts.com

MTS Systems (Germany) GmbH

Hohentwielsteig 3
14163 Berlin
Germany
Telephone: +49-(0)30 81002-0
E-mail: euroinfo@mts.com

MTS Systems S.R.L. a socio unico

Strada Pianezza 289
10151 Torino
Italy
Telephone: +39-(0)11 45175 11 sel. pass.
E-mail: mtstorino@mts.com

MTS Systems Norden AB

Datavägen 37b
SE-436 32 Askim
Sweden
Telephone: +46-(0)31-68 69 99
E-mail: norden@mts.com

MTS Systems Limited

98 Church Street,
Hunslet,
Leeds
LS102AZ
United Kingdom
Telephone: +44 (0) 113 270 8011
E-mail: mtsuksales@mts.com

ASIA/PACIFIC

MTS Japan Ltd.

Raiden Bldg. 3F 3-22-6,
Ryogoku, Sumida-ku,
Tokyo 130- 0026
Japan
Telephone: +81 3 5638 0850
E-mail: mts-j-info@mts.com

MTS Korea, Inc.

4th F., ATEC Tower, 289,
Pankyo-ro, Bundang-gu
Seongnam-si
Gyeonggi-do 13488,
Korea
Telephone: 82-31-728-1600
E-mail: mtsk-info@mts.com

MTS Systems (China) Co., Ltd.

Floor 34, Building B,
New Caohejing International
Business Center,
No.391, Guiping Road,
Xuhui District
Shanghai 200233
P.R.China
Telephone: +021-24151000
Market: 021-24151111
Sales: 021-24151188
Service: 021-24151198
E-mail: MTSC-Info@mts.com

MTS Testing Solutions Pvt Ltd.

Unit No. 201 & 202, Second Floor
Donata Radiance,
Krishna Nagar Industrial Layout,
Koramangala, Bangalore - 560029
Karnataka, India
Telephone: + 91 80 46254100
Email: mts.india@mts.com



MTS Systems

14000 Technology Drive
Eden Prairie, MN 55344-2290 USA

ISO 9001 Certified QMS
<http://www.mts.com>

Specifications subject to change without notice.

MTS is a registered trademark of MTS Systems in the United States. This trademark may be protected in other countries. RTM No. 211177.

© 2021 MTS Systems
100-592-536 Hydraulic Actuators 242 • Printed in U.S.A. • 09/21