



Series 293 Hydraulic Service Manifolds

Flexible, reliable hydraulic pressure and flow regulation

MTS SERIES 293 HYDRAULIC SERVICE MANIFOLDS (HSMs)

PROVIDE COMPLETE, INDEPENDENT CONTROL OF THE HYDRAULIC PRESSURE APPLIED TO INDIVIDUAL STATIONS OPERATING FROM A SINGLE HYDRAULIC POWER UNIT (HPU). DESIGNED TO MAKE TEST SYSTEM SETUP, OPERATION AND MAINTENANCE MORE CONVENIENT, THESE HSMs ENABLE OPERATORS TO ADJUST FLUID FLOW REDUCING THE RISK OF CROSS-TALK.



Flexible, modular design

Engineered to integrate seamlessly in a wide variety of MTS testing solutions. Series 293 HSMs offer many options to optimize operation with any test system. A choice of flow rates up to 946 lpm (250 gpm) and pressure designs up to 280 bar (4,000 psi) make it easy to align hydraulic fluid flow rate with individual system requirements, which helps conserve resources. These systems can also be configured to control up to four test systems independently. Combined with a compact design, this flexibility allows you to save valuable floor space in your lab.

Designed for safe, reliable operation

Installing these hydraulic pressure and flow regulation devices between the HPU and servovalve allows operators to turn each hydraulic circuit on and off, as well as set the low-pressure level. Smooth, controlled transitions enhance safety and make system control more predictable. By minimizing the effects of rapid application and removal

of high pressure, Series 293 HSMs reduce unexpected actuator movement that could damage test specimens.

Another way Series 293 HSMs help protect test specimens, test systems and operators is with rapid dump hydraulic pressure unloading. This feature quickly removes hydraulic pressure applied to the system in the event of abnormal or potentially hazardous conditions.

Pressure accumulators provide energy storage for peak performance, mitigating the need for a larger HPU. Accumulators in the pressure and return lines minimize pressure fluctuations, quieting the line and helping ensure reliable performance. Pilot pressure accumulators further enhance performance by reducing pressure flow fluctuations to the servovalve.

ENHANCED PERFORMANCE

Series 293 HSMs also include additional filtration to help keep hydraulic fluid clean. A main filter protects components by minimizing the passage of dirt particles

that may enter the system when hydraulic lines are opened or hydraulic fixtures added. Plus, models equipped with pilot pressure contain a 3 μm (absolute) pilot pressure filter to enhance servovalve and system performance.

If you are running multiple test stations with shared hydraulics, you may want to add an MTS Isolation Service Manifold (ISM). Designed as a companion to the Series 293 family, the ISM is placed between the HPU and HSM to prevent system over-pressurization, provide full system pressure discharge and allow for full hydraulic power isolation downstream of the device.

Four model choices

SERIES 293.1x

Total maximum flow is 189 lpm (50 gpm). This model is available with 1, 2, 3 or 4 independently controlled stations, each of which can deliver maximum flow. Pilot pressure (for control in advance of a switch to high pressure) is optional.

SERIES 293.2x

Total maximum flow is 378 lpm (100 gpm). This model offers 1, 2, 3 or 4 independently controlled stations. One station can deliver maximum flow. With multiple stations, each one can deliver up to 189 lpm (50 gpm) of flow, not to exceed 378 lpm (100 gpm) total flow. Pilot pressure is standard.

SERIES 293.3x

This model offers maximum flow of 946 lpm (250 gpm). Available only for single-station control, it can be configured with single or dual outlets. Pilot pressure is standard.

SERIES 293.4x

This customizable model is designed for the needs of ground vehicle test systems such as the Model 329 6 DOF Road Simulator and Model 320 Road Simulator. It features high-flow capacity within a compact footprint allowing the many unique forms of hydraulic control distribution to each pad/corner of these highly engineered sub-systems.

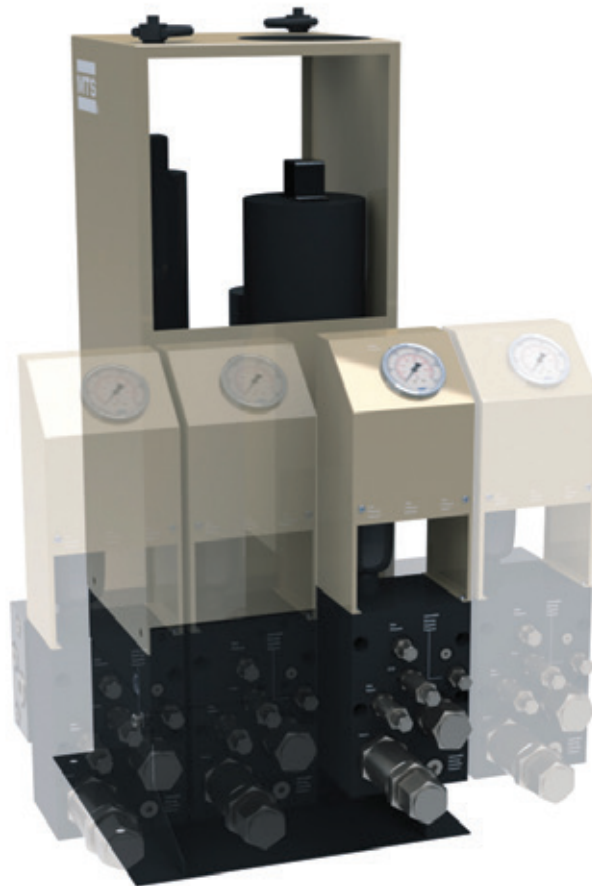

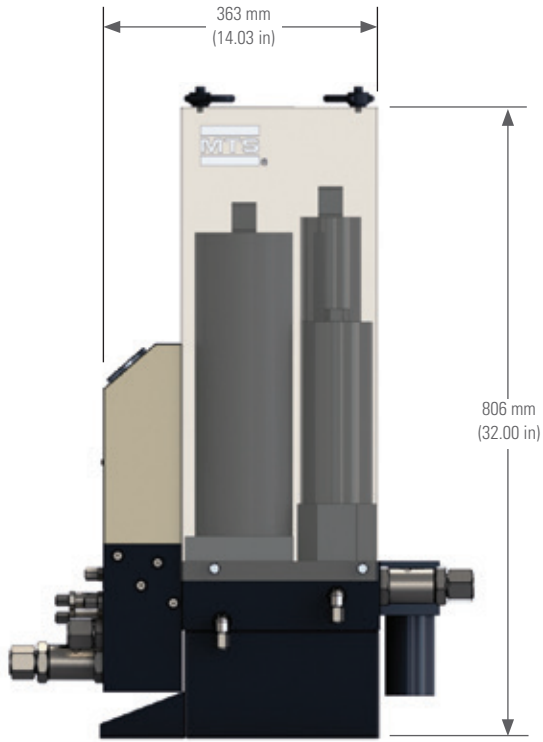

Model 293.1X
Single-, Dual-Station Configuration
Side View

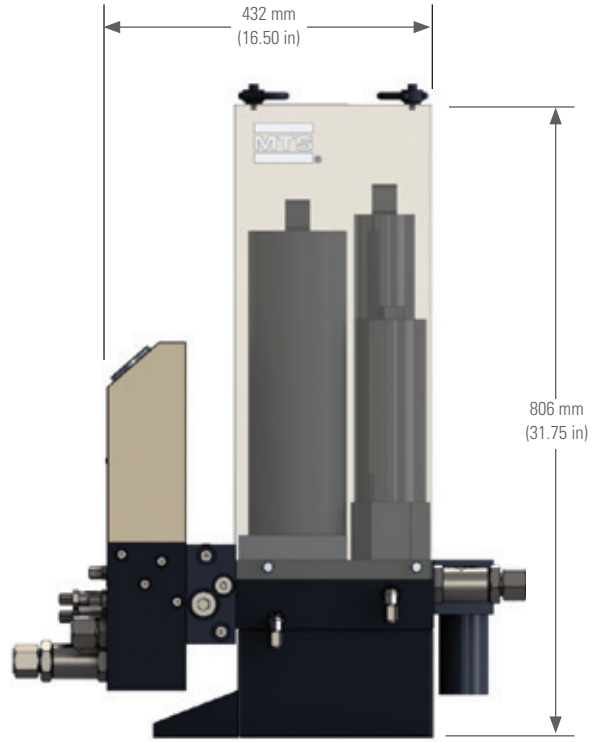

Model 293.1X
Multi-Station (3, 4) Configuration
Side View

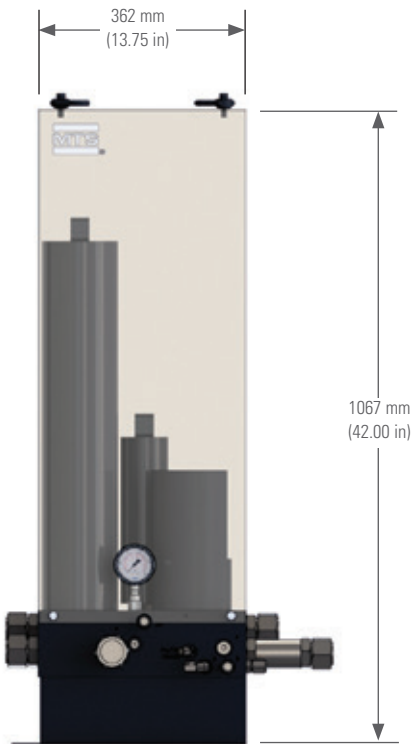

Model 293.22
Single-Station Configuration
Side View

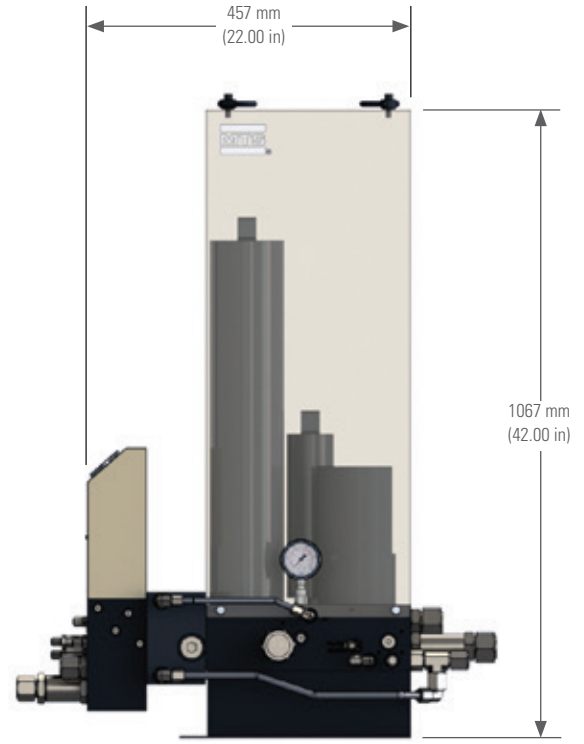

Model 293.22
Multi-Station Configuration
Side View

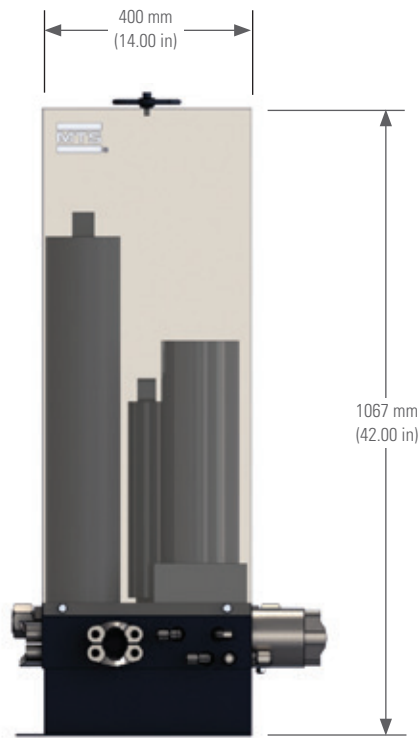

Model 293.24
Single-Station Configuration
Side View

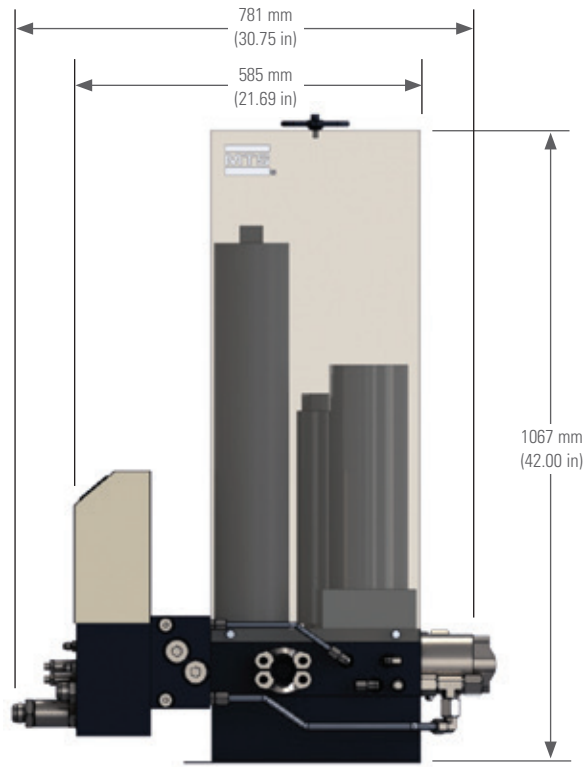

Model 293.24
Multi-Station Configuration
Side View

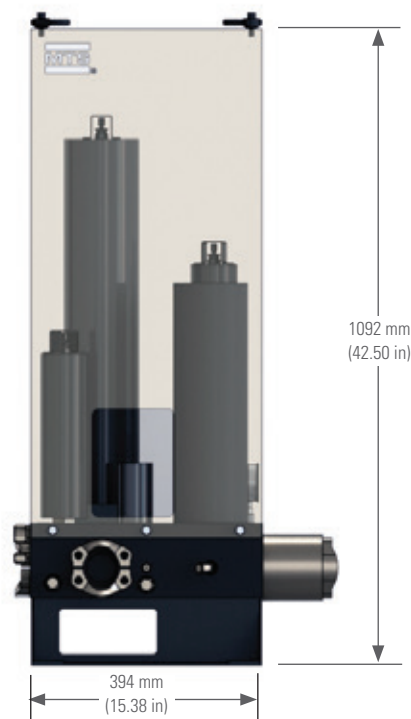

Model 293.32
Single-Station Configuration
Side View

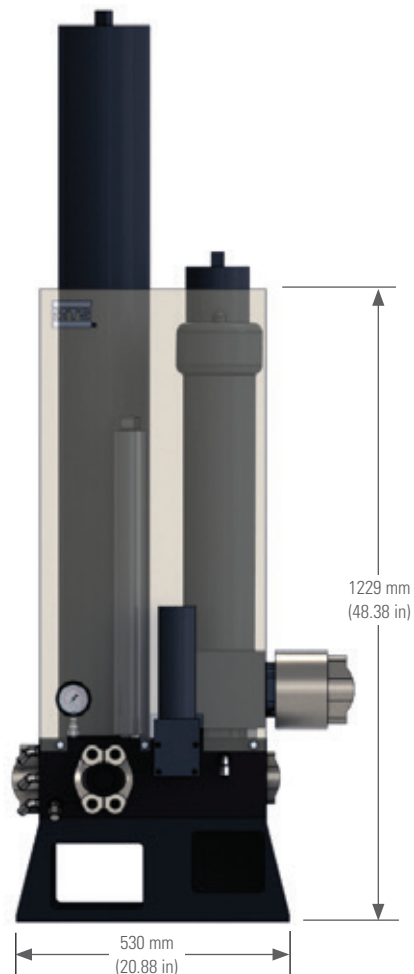

Model 293.34
Multi-Station Configuration
Side View

Managing flow with MTS Isolation Service Manifold

Turning your hydraulic distribution system on and off and responding to unexpected faults in the system in a controlled manner are essential to protecting your lab personnel, test specimens, test systems and lab environment. The MTS Isolation Service Manifold (ISM) allows you to control the hydraulic fluid flow through your test system during power on, power off and in the event of a system problem or E-stop, to help you better protect your lab personnel and assets. This consistent and purposeful control of hydraulic distribution also allows you to meet the most recent European Norm (EN) machinery safety standards, including EN 13121, EN 13849-1, and EN ISO 4413.

This manifold is placed between the hydraulic power unit (HPU) and the hydraulic service manifold (HSM) to prevent system over-pressurization, provide full system pressure discharge, and allow for full hydraulic power isolation downstream of the device. It is designed to work with MTS Series 293 and 298 HSMs, and MTS Series 497 and FlexTest® controllers, and can be adapted to work with other HPUs and HSMs. It is extremely easy to set up in a new system or you may add it to an existing test system using the cabling in the current system.

In the event of an unexpected system shutdown, the ISM performs a cascading sequence to bring the entire distribution system down in a controlled manner, while a redundant over-pressurization relief valve protects the test system nearest to the device. In addition to providing controlled sequences for powering on/off and responding to events, the ISM is easy to maintain. Its maintenance valve allows for efficient fluid draining that leaves just a residual coating of oil to make maintenance an easier, cleaner experience. Safely, consistently and carefully power on or power off your hydraulic distribution system and respond to potential hydraulic distribution issues with the MTS Isolation Service Manifold.



Specifications

	293.1X	293.22	293.24	293.32	293.34
Operating Pressure	21 MPa (3000 psi)	21 MPa (3000 psi)	28 MPa (4000 psi)	21 MPa (3000 psi)	28 MPa (4000 psi)
Nominal flow	189 lpm (50 gpm)	378 lpm (100 gpm)*	378 lpm (100 gpm)	946 lpm (250 gpm)	946 lpm (250 gpm)
Variable low pressure	1 - 21 MPa (150 - 3000 psi)	1 - 21 MPa (150 - 3000 psi)	1 - 28 MPa (150 - 4000 psi)	1 - 21 MPa (150 - 3000 psi)	1 - 28 MPa (150 - 4000 psi)
Slow on/off ramp time	5.0 - 9.0 seconds	5.0 - 9.0 seconds	5.0 - 9.0 seconds	5.0 - 9.0 seconds	5.0 - 9.0 seconds
Maximum current to solenoid valves	0.3 A at 115 V AC or 1.5 A at 24 V DC	0.3 A at 115 V AC or 1.5 A at 24 V DC	0.3 A at 115 V AC or 1.5 A at 24 V DC	0.3 A at 115 V AC or 1.5 A at 24 V DC	0.3 A at 115 V AC or 1.5 A at 24 V DC

ACCUMULATORS

Pressure	min	0.94 L (0.25 gal)	3.8 L (1 gal)	3.8 L (1 gal)	3.8 L (1 gal)	3.8 L (1 gal)
	max	3.8 L (1 gal)	7.6 L (2 gal)	7.6 L (2 gal)	19.0 L (5 gal)	19.0 L (5 gal)
Return	min	0.45 L (0.12 gal)	1.9 L (0.5 gal)	1.9 L (0.5 gal)	0.94 L (0.25 gal)	0.94 L (0.25 gal)
	max	0.94 L (0.25 gal)	3.8 L (1 gal)	3.8 L (1 gal)	7.6 L (2 gal)	7.6 L (2 gal)
Pilot pressure	min	0.45 L (0.12 gal)	0.45 L (0.12 gal)	0.45 L (0.12 gal)	0.45 L (0.12 gal)	0.45 L (0.12 gal)
	max	0.94 L (0.25 gal)	0.94 L (0.25 gal)	0.94 L (0.25 gal)	0.9 L (0.25 gal)	0.94 L (0.25 gal)

FLUID FILTRATION

Main supply	10 µm	74 µm	25 µm	25 µm	17 µm
Pilot pressure supply	3 µm	3 µm	3 µm	3 µm	3 µm

FLUID HOSE CONNECTIONS

Pressure	-16	-20 [†]	-20 SAE Code 62	-32 SAE Code 61	-32 SAE Code 62
Return	-16	-20 [‡]	-06	-32 SAE Code 61	-32 SAE Code 61
Pilot pressure	-06	-06	-06	-06	-06
Pilot return	-06	-06	-06	-06	-06
Drain	-06	-06 IN, -08 OUT**	-06 IN, -08 OUT	-06 IN, -08 OUT	-06 IN, -08 OUT
Hydrostatic bearing	-06	-06***	-04	-06	-06
Maximum number of stations/channels	4	4	4	1	1

DIMENSIONS AND WEIGHTS

Weight	70 kg (155 lb)	159 kg (350 lb) ¹	182 kg (400 lb) ¹	181 kg (400 lb) ²	227 kg (500 lb) ¹
Height	806 mm (31.75 in)	1067 mm (42 in) max	1067 mm (42 in)	1092 mm (43.5 in) ³	1229 mm (48.38 in)
Width (base)	363 mm (14.3 in)	362 mm (14.25 in)	362 mm (14.25 in)	403 mm (15.9 in) max	387 mm (15.25 in)
Depth (base)	359 mm (14.1 in)	394 mm (15.5 in)	400 mm (15.75 in)	394 mm (15.5 in) max	530 mm (20.9 in)

Footnotes:

* 378 lpm (100 gpm) total, 189 lpm (50 gpm) per station maximum for multi-station flow

[†] In a multi-station configuration, pressure -20 IN and -16 OUT

[‡] In a multi-station configuration, return -16 IN and -20 OUT

** In a multi-station configuration, HSM -06 IN and -12 OUT

*** In a multi-station configuration

¹ Standard size for single-station configuration; 227 kg (500 lb) maximum weight for four-station HSM

² Standard size; with optional accumulator capacity the weight is 454 kg (1000 lb) maximum

³ Standard size; with optional accumulator capacity the height is 2134 mm (84 in) maximum

Specifications are subject to change without notice. Contact MTS for verification of any critical specifications.

Note: Accumulator may extend beyond HSM height.

Regional Business Centers

THE AMERICAS

MTS Systems Corporation

14000 Technology Drive
Eden Prairie, MN 55344-2290

USA

Telephone: 952-937-4000
Toll Free: 800-328-2255
E-mail: info@mts.com
Internet: www.mts.com

EUROPE

MTS Systems France

BAT EXA 16
16/18 rue Eugène Dupuis
94046 Créteil Cedex

France

Telephone: +33-(0)1-58 43 90 00
E-mail: contact.france@mts.com

MTS Systems (Germany) GmbH

Hohentwielsteig 3
14163 Berlin

Germany

Telephone: +49-(0)30 81002-0
E-mail: euroinfo@mts.com

MTS Systems S.R.L. a socio unico

Strada Pianezza 289
10151 Torino

Italy

Telephone: +39-(0)11 45175 11 sel. pass.
E-mail: mtstorino@mts.com

MTS Systems Norden AB

Datavägen 37b
SE-436 32 Askim

Sweden

Telephone: +46-(0)31-68 69 99
E-mail: norden@mts.com

MTS Systems Limited

98 Church Street,
Hunslet,
Leeds
LS102AZ

United Kingdom

Telephone: +44 (0) 113 270 8011
E-mail: mtsuksales@mts.com

ASIA/PACIFIC

MTS Japan Ltd.

Raiden Bldg. 3F 3-22-6,
Ryogoku, Sumida-ku,
Tokyo 130- 0026

Japan

Telephone: +81 3 5638 0850
E-mail: mtsj-info@mts.com

MTS Korea, Inc.

2nd F, Bundang Yemiji Building, 31,
Hwangsaoul-ro 258beon-gil,
Bundang-gu, Seongnam-si,
Gyeonggi-do, 13595

Korea

Telephone: +82-31-728-1600
E-mail: mtsk-info@mts.com

MTS Systems (China) Co., Ltd.

Floor 34, Building B,
New Caohejing International
Business Center,
No.391, Guiping Road,
Xuhui District
Shanghai 200233

P.R.China

Telephone: +021-24151000
Market: +021-24151111
Sales: +021-24151188
Service: +021-24151198
E-mail: MTSC-Info@mts.com

MTS Testing Solutions Pvt Ltd.

Unit No. 201 & 202, Second Floor
Donata Radiance,
Krishna Nagar Industrial Layout,
Koramangala, Bangalore - 560029
Karnataka, India
Telephone: + 91 80 46254100
Email: mts.india@mts.com



MTS Systems Corporation

14000 Technology Drive
Eden Prairie, MN 55344-2290 USA

ISO 9001 Certified QMS
<http://www.mts.com>

MTS is a registered trademark of MTS Systems Corporation. This trademark may be protected in other countries. RTM No. 211177.

©2023 MTS Systems
100-242-720b HSM 293 • Printed in U.S.A. • 08/23