

ISO 527-3 Tensile Properties of Plastic Films and Sheets

TEST METHOD SUMMARY

To properly identify and characterize plastic films and thin sheeting materials for both quality control and specification purposes, ISO 527-3 is one of the more widely used test methods in the industry. This tensile test is similar to ISO 527-2 but is specifically for materials that are less than 1mm (0.04”) thick. These tensile tests are used to measure factors such as tensile and yield strength, tensile strength at break, and occasionally Young’s modulus. This important test is used in many ways, from specifying a new material for a packaging application, to designing a new part that will withstand a known application force, to performing routine quality control checks of incoming raw materials. Knowing that the physical properties of many of these materials are quite sensitive to varying temperatures, it may be necessary to test the materials at the temperatures that simulate their intended use conditions.

In this procedure, place specimen in the grips of the universal test machine and pull until failure. Proper gripping of these fragile specimens is often the biggest challenge to collecting reliable data. The grips must secure the specimen enough to prevent slipping but at the same time not induce local stresses that cause tearing and premature failure. This test method is similar to ASTM D882, but technically not equivalent since ISO 527-3 allows for additional specimen configurations, specifies different test speeds, and requires an extensometer or gage marks on the specimen. This test method is also not suitable for cellular materials or fibre reinforced plastics.

Solutions for ISO 527-3 typically include these types of components;

LOAD FRAME OPTIONS*

Both the premium MTS Criterion® and the economical MTS Exceed® universal testing machines are ideal for testing of plastic films and sheets per ISO 527-3. They both come in a variety of force capacities and frame styles, ranging from 1-column tabletops to larger 2-column floor-standing models. The 30kN and 100kN models also have dual-zone test spaces to reduce set-up times if you frequently change test requirements. And as an alternative to a new load frame, you can modernize the software and controls of your old test system with an MTS ReNew™ Upgrade.





MTS Criterion®
Electromechanical Universal Test Systems



MTS Exceed®
Electromechanical Universal Test Systems

GRIP OPTIONS*



	
Pneumatic Grips	Roller Grips
<ul style="list-style-type: none"> » Vise & Wedge style grips provide constant clamping force to minimize slippage » Most commonly used for qa/qc testing » Many different faces and larger specimen opening for universal testing needs » Fast and easy operation 	<ul style="list-style-type: none"> » Smoother rubber face and smooth compression bar work well for thin films but not for many other applications » Quick and easy to set up

GRIP FACE OPTIONS*

		ISO 527-3 Gripping Guidance
<ul style="list-style-type: none"> » Best option for thin or easily damaged specimens 	<ul style="list-style-type: none"> » Sometimes a combination of rubber coated faces and line contact faces work best 	<p>The grips must secure the specimen enough to not allow any slipping but at the same time not induce local stresses that cause tearing and premature failure. For all tests, the grip face width should be wider than the specimen under test.</p>

EXTENSOMETRY OPTIONS*

The stress strain curves for thin films may contain a linear elastic region, as well as a large non-linear plastic region. Total elongation is best measured with an extensometer. The fragility of the thin film sample requires an extensometer with a low tracking force or even a non-contacting extensometer.

	
Contacting - High Elongation	Non-contacting - Video
MTS Advantage™ AHX850 High Elongation Extensometer has an adjustable, low-impact specimen contact force that can be used for most thin film and plastic sheeting materials.	MTS Advantage™ Video Extensometer (AVX) delivers the highest quality in non-contact strain measurement. This solution is ideal when specimens are particularly fragile or there is a desire for multiple strain measurements.

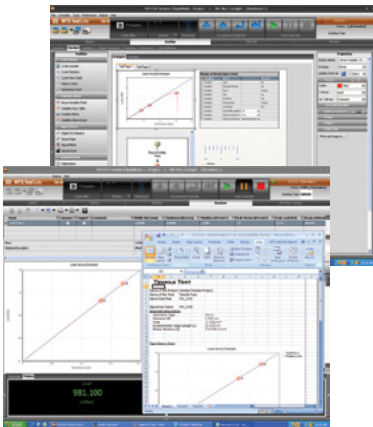

SOFTWARE OPTIONS*

ISO 527-3 Tensile Strength Test Template	About TestSuite™ TW
<p>To simplify testing to ISO 527-3, MTS has developed a TestSuite™ TW test template that will set-up and run the recommended tensile tests. After the test data has been collected, reports will display all of the required calculations including tensile and yield strength, tensile strength at break, and Young's Modulus, and more.</p> <p>MTS consultants are also available to support any of your plastic thin film / sheeting test applications, test method set-up, and data collection and integration requirements.</p>	<p>This flexible and versatile software application comes in three versions so that you can choose exactly which one best fits your requirements. Lab managers and test creators like TW Elite since it includes all the test definition capacity and flexibility needed to create and edit custom test sequences while accommodating the specific runtime needs of lab personnel. Test operators prefer the simplicity and intuitive nature of TW Express. This software allows operators to easily execute tests and monitor data or calculated values in runtime views. For QA/QC labs that prefer the MTS Exceed universal test machine, TW Essential will provide both the test creation and test operation capabilities, combining efficiency and productivity in one software application.</p>

*NOTE: This technical note is intended to show some of the popular and more common solutions used for this particular application. Most of the time, additional options are available and necessary to accomplish your more comprehensive test objectives.

APPENDIX - TEST SPECIMEN DETAIL

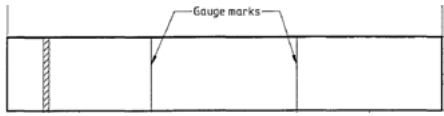
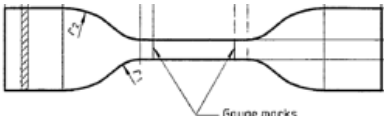
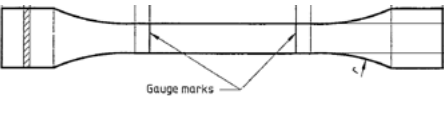
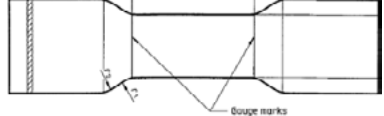
Type 2 - Preferred Format	Type 5 - Routine QC Tests for Very High Strain at Break
	
Type 1B - Routine QC Tests for Rigid Sheets	Type 4 - Routine QC Tests for other Thermoplastics
	



MTS Systems Corporation
 14000 Technology Drive
 Eden Prairie, MN 55344-2290 USA
 Telephone: 1-952-937-4000
 Toll Free: 1-800-328-2255
 E-mail: info@mts.com
 www.mts.com

ISO 9001 Certified QMS

MTS, MTS Criterion, and MTS Exceed are registered trademarks, and TestSuite and ReNew are trademarks of MTS Systems Corporation within the United States. These trademarks may be protected in other countries. RTM No. 211177.

© 2021 MTS Systems Corporation
 100-332-954 TMTN1527_3 Printed in U.S.A. 09/21