

Series 248 Hydraulic Actuators



Benefits

- ▶ Hydrostatic pressure-centering bearings for continuous high speed operation under heavy side loaded conditions.
- ▶ Large-diameter, single-piece, chrome-plated piston rod provides strength and lateral stiffness.
- ▶ Thick-walled cylinder for overall rigidity and high transverse resonant frequency.
- ▶ Displacement transducer is coaxially mounted within the hollow piston rod for simple construction, increased accuracy, and transducer protection.
- ▶ Standard built-in hydraulic cushions protect the end caps during full-stroke, high-velocity operation.
- ▶ Accepts a wide range of servovalves from 1 to 90 gpm (4 to 340 L/min). Special porting and cushions are available as an option for flow requirements greater than 90 gpm (340 L/min).
- ▶ Optional static support assembly uses pressurized nitrogen to offset the weight of a heavy specimen or fixture that is used with the actuator. This reduces power requirements on the hydraulic system.

Description

The Series 248 Hydraulic Actuators are heavy-duty, double-ended, linear force generating actuators that operate under precision servovalve control in MTS closed-loop testing systems. The Series 248 Actuators are designed specifically for low friction, low distortion, high sideload, vibration testing of structures and components.



Options

The following options are available with the Series 248 Actuators. Contact MTS Systems Corporation for additional information on these options.

Porting

- ▶ Optional porting can be provided to accommodate flow requirements greater than 90 gpm (340 L/min).

LVDT

- ▶ This option provides a piston rod displacement feedback signal to the system control electronics. The LVDT coil is secured to either the pedestal base, static support, or open housing assembly.

Pedestal Base

- ▶ The pedestal base allows the actuator to be mounted to a reaction mass for free-standing vibration testing.

Static Support Assembly

- ▶ This option is used when it is desirable to support a heavy structure or component on the actuator piston rod without using hydraulic pressure to offset the weight of the specimen.

Typical Series 248 Hydraulic Actuator assembly shown with optional servovalve, manifold, accumulators, differential pressure cell, and other accessories

Design Characteristics

MTS actuators are manufactured to close tolerances to ensure reliability, long life, and complete part interchangeability (within a given actuator model). The following characteristics are common to all Series 248 Actuators.

Piston Rod End (fixture attachment end)

Has a center position internal thread and an internal thread circular hole pattern for mounting fixtures, vibration tables, wheel pans, load cell, etc.

Porting

Hydraulic fluid is ported into the actuator through the retraction port or the extension port. The fluid flow is regulated by a servovalve. As high hydraulic pressure is applied to one port, the other port is opened to a return line, resulting in actuator rod displacement.

Piston Rod

The double-ended piston has equal areas on both sides for balanced performance. It is machined from a single piece of heat-treated alloy steel, hard chrome plated, and precision ground to a fine finish to increase seal and bearing life. The hollow piston rod permits convenient installation and accurate alignment of the LVDT.

Piston Seal

The close tolerance fit between the piston and cylinder provides an effective viscous seal. Grooves on the piston ensure adequate lubrication of the piston surface during short-stroke, sideloaded tests.

Hydrostatic Bearings

Each end cap contains four bearing pads which provide a strong centering force to counteract side loads.

Piston Rod Seals

One seal assembly is provided in each end cap. This assembly contains a seal which guides excess hydraulic fluid to the drainback port, and a wiper which prevents external contamination from entering the actuator.

Pedestal Base

Allows the actuator to be mounted to a reaction mass for vibration testing.

LVDT

This assembly provides a signal proportional to actuator displacement. The LVDT core is secured inside the hollow piston rod by a core mount. On the pedestal base and open housing configurations, the core mount can be adjusted to establish a zero reference point for the actuator. The static support configuration has a fixed core mount to provide a mid-stroke zero reference point.

Static Support (not shown)

The Series 248 Actuators may be used in a static support configuration when it is desirable to support a heavy specimen or fixture on the piston rod without using hydraulic pressure to offset the weight of the specimen or the fixture. The static support assembly is mounted to the lower end cap of the actuator.

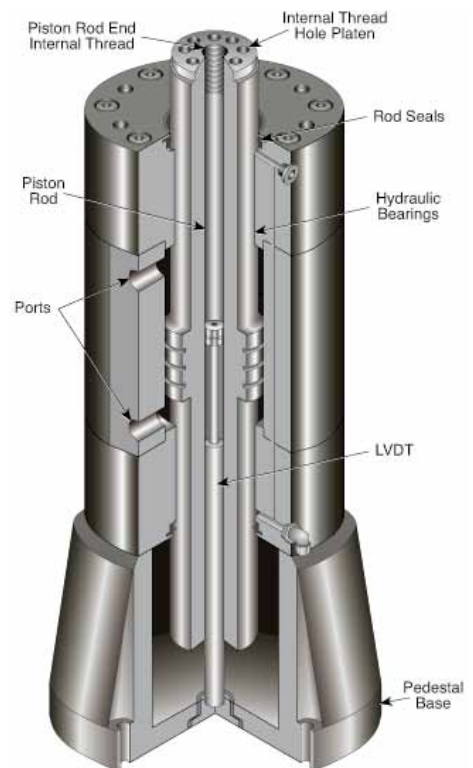
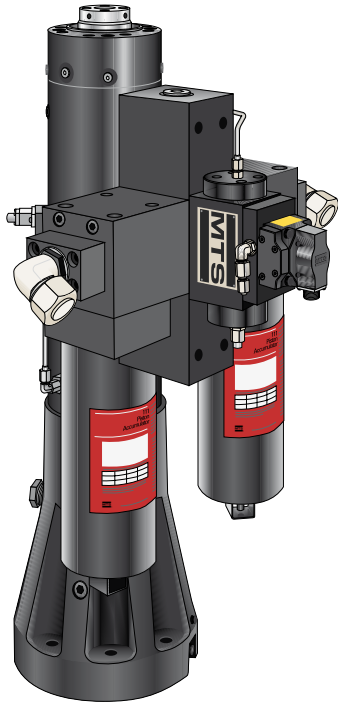

Cutaway View of a Typical Series 248 Actuator

Specifications

Specifications for the Series 248 Actuators are listed according to actuator model numbers. Other tables list the dimensions for the basic cylinder assembly shown. The open housing and pedestal base configurations are shown on the next page.

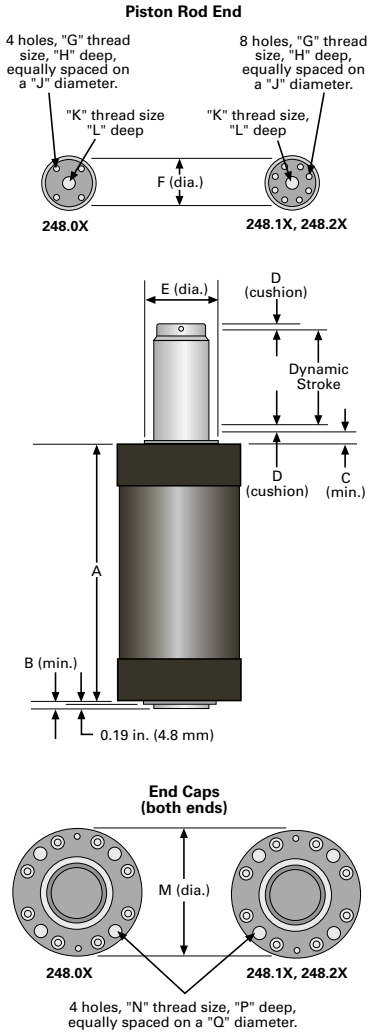

Basic Cylinder Assembly Dimensional Drawing

Series 248 Actuator Specifications

Model	Force Rating		Piston Area		Rod Diameter	
	Kip	kN	in. ²	cm ²	in.	mm
248.01	2.2	10	0.81	5.23	3.15	80.0
248.02	3.5	16	1.29	8.32	3.15	80.0
248.03	6.2	28	2.25	14.52	3.15	80.0
248.04	8.5	38	3.10	20.00	3.15	80.0
248.05	11.0	50	3.98	25.67	3.15	80.0
248.11	22.0	100	7.87	50.77	3.94	100.0
248.12	35.0	160	12.60	81.29	3.94	100.1
248.21	55.0	250	19.69	127.03	4.92	125.0

Specifications are subject to change without notice. Contact MTS for verification of specifications critical to your needs.

Basic Cylinder Assembly Dimensions (Stroke Length Dependent)

Dynamic Stroke Length	248.0X		A		248.2X		B		C		D		
	in.	mm	in.	mm	in.	mm	in.	mm	in.	mm	in.	mm	
1	25.4	11.89	302.0	12.29	312.1	13.61	345.7	0.38	9.6	1.25	31.8	0.38	9.6
2	50.8	12.89	327.4	13.29	337.5	14.61	371.1	0.38	9.6	1.25	31.8	0.38	9.6
4	101.6	15.64	396.2	16.04	407.4	17.36	441.0	0.38	9.6	1.25	31.8	0.75	19.1
6	152.4	17.64	448.0	18.04	458.2	19.36	491.8	0.38	9.6	1.25	31.8	0.75	19.1
8	203.2	19.64	498.8	20.04	509.0	21.36	542.6	0.38	9.6	1.25	31.8	0.75	19.1
10	254.0	21.64	549.6	22.04	559.8	23.36	593.4	0.38	9.6	1.25	31.8	0.75	19.1

Specifications are subject to change without notice. Contact MTS for verification of specifications critical to your needs.

Basic Cylinder Assembly Dimensions (Model Number Dependent)

Model	E		F		G	H		J		K
	in.	mm	in.	mm		in.	mm	in.	mm	
248.0X	4.49	114.0	3.15	80.0	M12 x 1.75 mm	0.88	22.4	2.25	57.2	M27 x 2 mm
248.1X	5.25	133.4	3.94	100.0	M12 x 1.75 mm	0.88	22.4	2.76	70.0	M27 x 2 mm
248.2X	6.30	160.0	4.92	125.1	M16 x 2 mm	1.00	25.4	3.54	90.0	M36 x 3 mm

Model	L		M		N	P		Q	
	in.	mm	in.	mm		in.	mm	in.	mm
248.0X	2.00	50.8	6.75	170.0	M20 x 2.5 mm	0.94	23.9	5.38	136.5
248.1X	2.00	50.8	8.75	222.2	M24 x 3 mm	1.00	25.4	6.75	171.5
248.2X	2.50	63.5	10.69	271.5	M24 x 3 mm	1.50	38.1	9.06	230.0

Specifications are subject to change without notice. Contact MTS for verification of specifications critical to your needs.

Open Housing LVDT Dimensions

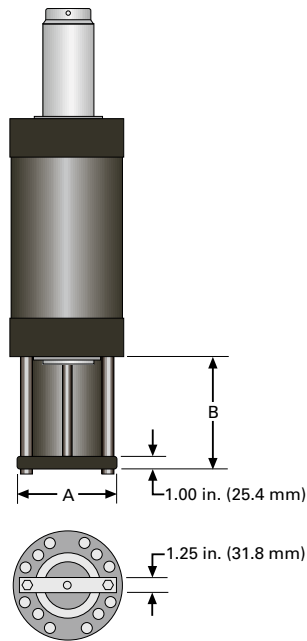

Open Housing LVDT Dimensional Drawing

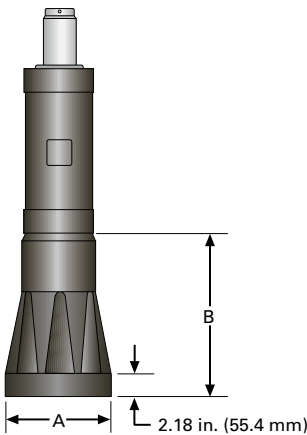

Pedestal Base Dimension Drawing

Model	A		B					
	in.	mm	1 in. (25.4 mm) and 2 in. (50.8 mm) Stroke		4 in. (101.6 mm) and 6 in. (152.4 mm) Stroke		8 in. (203.2 mm) and 10 in. (254.0 mm) Stroke	
	in.	mm	in.	mm	in.	mm	in.	mm
248.0X	6.50	165.1	4.25	107.6	9.00	228.6	13.00	330.2
248.1X	7.75	196.9	4.25	107.6	9.00	228.6	13.00	330.2
248.2X	9.00	228.6	4.25	107.6	9.00	228.6	13.00	330.2

Specifications are subject to change without notice. Contact MTS for verification of specifications critical to your needs.

Pedestal Base Dimensions

Model	A		B		C		D		E	F		G	
	in.	mm	in.	mm	in.	mm	in.	mm		in.	mm	in.	mm
248.0X	10.5	266.7	5.75 ¹	146.1 ¹	0.53	13.5	9.00	228.6	3/4"-10 UNC-2B	1.0	25.4	9.0	228.6
	10.5	266.7	10.50 ²	266.7 ²	0.53	13.5	9.00	228.6	3/4"-10 UNC-2B	1.0	25.4	9.0	228.6
	10.5	266.7	14.50 ³	368.3 ³	0.53	13.5	9.00	228.6	3/4"-10 UNC-2B	1.0	25.4	9.0	228.6
248.1X	10.5	266.7	16.50 ⁴	419.1 ⁴	0.53	13.5	9.00	228.6	3/4"-10 UNC-2B	1.0	25.4	9.0	228.6
	13.5	342.9	5.25 ¹	133.4 ¹	0.66	16.8	11.81	300.0	1"-8 UNC-2B	1.5	38.1	11.0	279.4
	13.5	342.9	10.50 ²	266.7 ²	0.66	16.8	11.81	300.0	1"-8 UNC-2B	1.5	38.1	11.0	279.4
248.2X	13.5	342.9	14.50 ³	368.3 ³	0.66	16.8	11.81	300.0	1"-8 UNC-2B	1.5	38.1	11.0	279.4
	13.5	342.9	16.50 ⁴	419.1 ⁴	0.66	16.8	11.81	300.0	1"-8 UNC-2B	1.5	38.1	11.0	279.4
	16.5	419.1	5.25 ¹	133.4 ¹	0.91	23.1	14.57	370.0	-	-	-	-	-
248.2X	16.5	419.1	10.50 ²	266.7 ²	0.91	23.1	14.57	370.0	-	-	-	-	-
	16.5	419.1	14.50 ³	368.3 ³	0.91	23.1	14.57	370.0	-	-	-	-	-
	16.5	419.1	16.50 ⁴	419.1 ⁴	0.91	23.1	14.57	370.0	-	-	-	-	-

1. Applies to actuators with 1 or 2 in. (25.4 or 50.8 mm) stroke.
2. Applies to actuators with 4 or 6 in. (101.6 or 152.4 mm) stroke.
3. Applies to actuators with 8 or 10 in. (203.2 or 254.0 mm) stroke.
4. Applies to actuators with 12 in. (304.8 mm) stroke.
5. Dimension is 5.25 in. (133.4 mm) for 248.1X and 248.2X actuators with a 1 in. (25.4 mm) or 2 in. (50.8 mm) stroke. This dimension and dimension 'B' are one and the same for these models.

Ordering Information

When ordering a Series 248 Actuator, first specify the desired basic cylinder assembly. The basic cylinder assembly is ordered by the model number corresponding to the desired force rating and the desired stroke length. Next, specify the desired options as follows:

- ▶ Special Porting
- ▶ Open Housing LVDT Configuration
- ▶ Pedestal Base Configuration
- ▶ Static Support Configuration

MTS Systems Corporation
 14000 Technology Drive
 Eden Prairie, Minnesota 55344-2290 USA
 Toll Free: 800-328-2255
 Phone: 952-937-4000 Fax: 952-937-4515
 E-mail: info@mts.com
 www.mts.com

ISO 9001 CERTIFIED QMS

Specifications subject to change without notice. MTS and RPC are registered trademarks of MTS Systems Corporation. RTM No. 211177. © 1999 MTS Systems Corporation. 100-016-994 HydAct248-01 Printed in U.S.A. 10/99